

## Data sheet 4HB 610

Performance curve for Vacuum pump

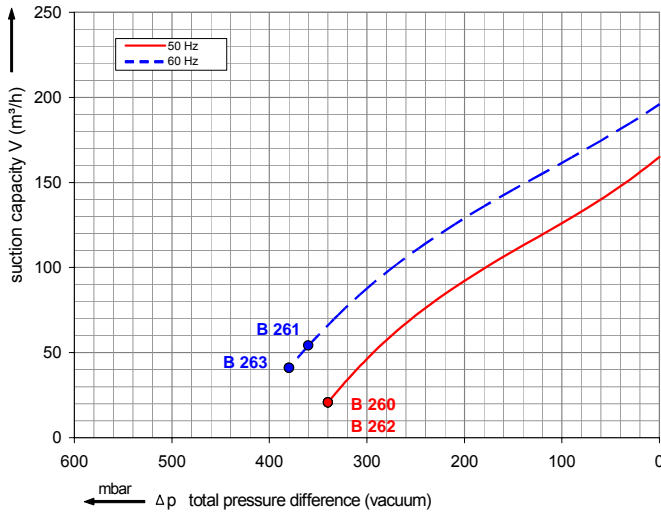

Performance curve for Compressor

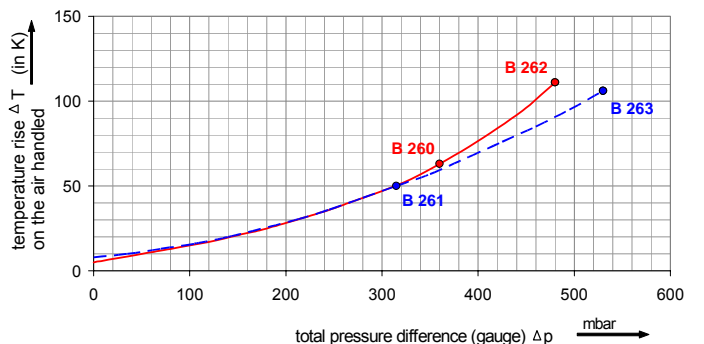
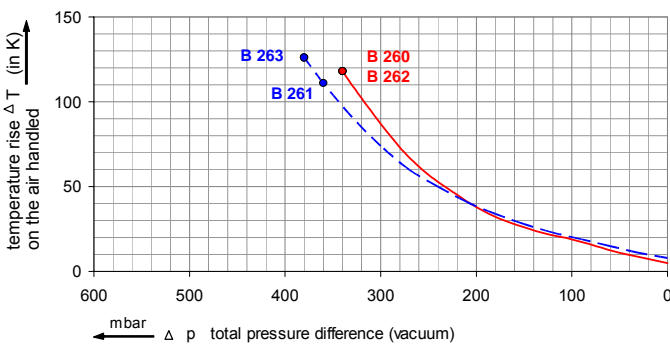
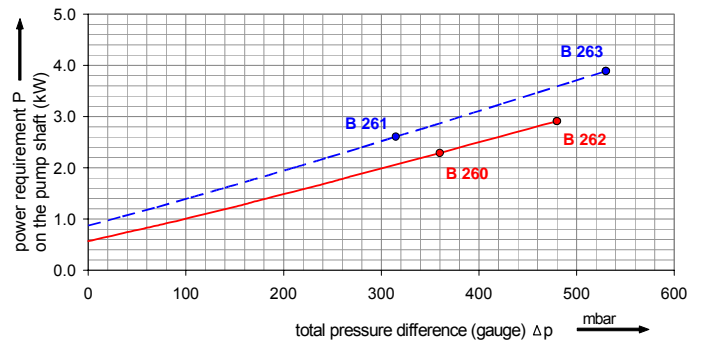
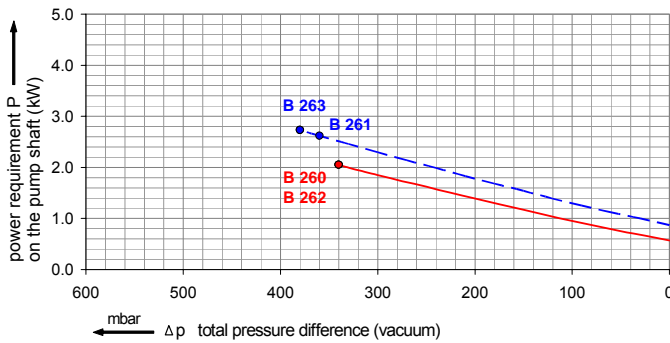
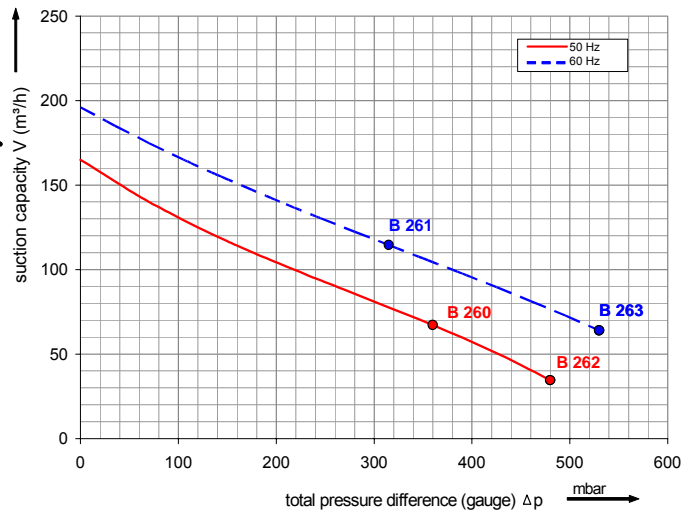

The performance curves are based on air at a temperature of 15 °C and an atmospheric pressure of 1013 mbar with a tolerance of +/- 10 %. The total pressure differences are valid for suction and ambient temperatures up to 25 °C. For other conditions please confer with us.

Each G-4RB type can be applied both as vacuum pump and compressor in continuous operation over the total stated performance curve range. The motors are available as standard for the input voltage range of 50 and 60 Hz and for protection category IP 55 as well as approved for UL and CSA.



## Data sheet 4HB 610

### Selection and ordering data

#### Type 4HB 610

Curve No.	Order No.	Fre- quency	Rated power	Input voltage		Input current	Permissible total differential pressure <sup>2)</sup>		Sound pressure level <sup>3)</sup>	Weight ca.
							Vacuum mbar	Compressor mbar		
		Hz	kW	V		A			dB(A)	kg

#### 3- 50/60 Hz IP55 insulation material class F 1)

B 260	4HB 610-220T	50	2.2	200D ... 240D	345Y ... 415Y	11.4D	6.6Y	-340	360	65	32
B 261	4HB 610-220T	60	2.55	220D ... 275D	380Y ... 480Y	11.2D	6.5Y	-360	315	71	32
B 262	4HB 610-330T	50	3.3	200D ... 240D	345Y ... 415Y	13.0D	7.5Y	-340	480	65	35
B 263	4HB 610-330T	60	3.8	220D ... 275D	380Y ... 480Y	14.2D	8.2Y	-380	530	71	35

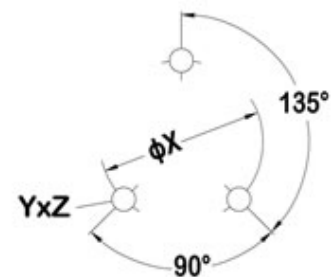
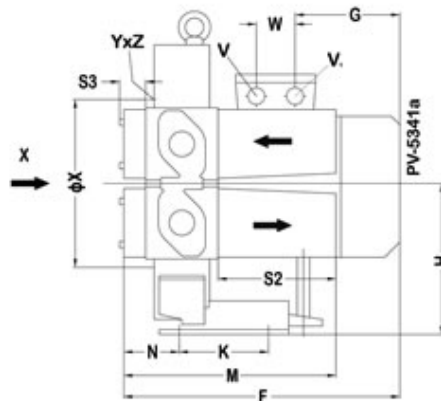
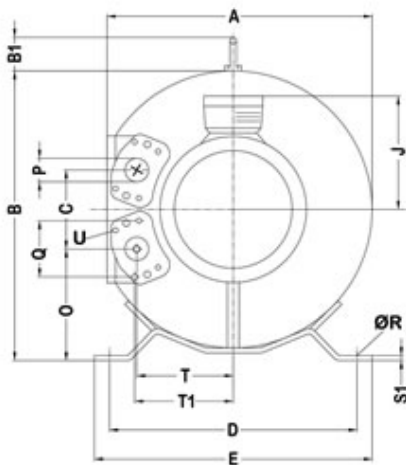

<b>A</b>	<b>B</b>	<b>C</b>	<b>D</b>	<b>E</b>	<b>F</b>		
418	455	127	371	406	364		
<b>G</b>	<b>H</b>	<b>J</b>	<b>K</b>	<b>M</b>	<b>N</b>	<b>O</b>	
	185	235	128	152	271	72	172
<b>P</b>	<b>Q</b>	<b>φR</b>	<b>S1</b>	<b>S2</b>	<b>S3</b>	<b>T</b>	<b>T1</b>
G 1 ¼	64	14	4	140	31	153	155
<b>U</b>	<b>V</b>	<b>V1</b>	<b>W</b>	<b>φX</b>	<b>Y_Z</b>		
M6×17	M25×1.5	M16×1.5	32	228	M8×15		

All 4HB achieve the standards and norms of the low voltage directive (LVD)2006/95/EC, rotating electrotechnical motor EN 60034-1-2004, electromagnetic compatibility(EMC)EN55014-1/2,EN61000-2/-3/-4/-6.

- 1) For standard UL for ELECTRIC MOTOR UL 1004-1.
- 2) Relief-valve are available for limiting differential pressure.
- 3) Measuring-surface sound-pressure level acc. to DIN EN 21680, measured at a distance of 1 m. The pump is throttled to an average suction pressure, a hose is connected to the discharge side (compressor) / suction side (vacuum pump), but is not fitted with relief valves.

The motors are designed according to the DIN EN 60 034 / DIN IEC 34-1 and temperature class F.

For the three phase machines the tolerances are +/- 10 % for fixed voltage and +/- 5 % for voltage range.

The single phase machines are designed with a +/- 5 % tolerances. If only 90 % of the maximum allowed pressure will be used for the continuous operating then the allowed voltage range add to +/- 10 %.

For all single and three phase machines which designed according to the UL and CSA norm (UL 1004-1) the maximum allowed voltage tolerances are - 10 % resp. + 6 %.

The frequency tolerance is maximum +/- 2 %.